



TECH NOTE:	08-007
TITLE:	Procedure for hydraulic pressure release without system power.
DATE:	08/5/08
REVISION:	1.1

Description: This document describes the procedures to use in the event that you need to release fluid pressure from a Cirus hydraulic manifold assembly when you do not have system power available (pump or engine non-functional).

Normal procedure: each valve section contains a “red” manual over-ride button that can be actuated to move hydraulic fluid in the selected direction of motion when system power functions, but you need to actuate the function from the valve assembly instead of from the control system in the vehicle cab.

WARNING		<p>Potential for injury due to unexpected startup or movement of mechanical equipment.</p> <p>Unexpected startup or movement of mechanical equipment may cause injury to eyes and extremities.</p> <p>During initial startup and testing, the spreader components may start without warning. Stay clear of the auger, spinner, and liquid nozzles until initial power up and programming are complete.</p>
----------------	---	--

Procedure for Releasing Hydraulic Pressure When System Power is non-functional

1) To Lower a Dump Body Hoist – Identify the valve part number

- a. **HYDJ05 – 35gpm, DA cylinder section with counterbalance valve:** with truck engine off, loosen locknut on the counterbalance valve (item 2 on attached drawing). Slowly, turn adjusting screw clockwise, while counting turns, to reduce setting and lower the load. The load will begin to move when the setting is low enough. After the load has been lowered, return adjusting screw to original setting and tighten the locknut.

2) To Raise/Lower implement (Hoist, Plow, Wing or Blade) - Identify the valve part number

Lifting of an implement, adjust port relief of the return side of the valve (usually port A).
Lowering an implement, adjust port relief of the pressure side of the valve (usually port B).

a. **HYDJ09 – 20gpm, DA, cylinder section:**

- i. With truck engine turned off, identify the desired port relief valve, (item 5 on drawing), and loosen the locknut. Slowly turn the adjusting screw counterclockwise while counting the turns, all the way until it stops. The pressure setting at the full counterclockwise position will be 250psi.

Now, an external source (winch, fork lift, etc) may be used to lift/lower the implement into the desired position. After the implement has been moved, return adjusting screw to original position and tighten locknut.

b. **HYDJ06 – 10gpm, DA, cylinder section:**

- i. With truck engine turned off, identify the desired port relief valve, (item 7 on drawing), and loosen the locknut. Slowly turn the adjusting screw counterclockwise while counting the turns, all the way until it stops. The pressure setting at the full counterclockwise position will be 250psi.

Now, an external source (winch, fork lift, etc) may be used to lift/lower the implement into the desired position. After the implement has been moved, return adjusting screw to original position and tighten locknut.

ASSEMBLY PART NUMBER
STAMPED IN HERE
EXAMPLE:
"HYDJ103050606"

MAIN SYSTEM RELIEF

ALL PORTS MARKED
ON BOTTOM OF VALVE

SPREADER SECTION
ALWAYS FIRST

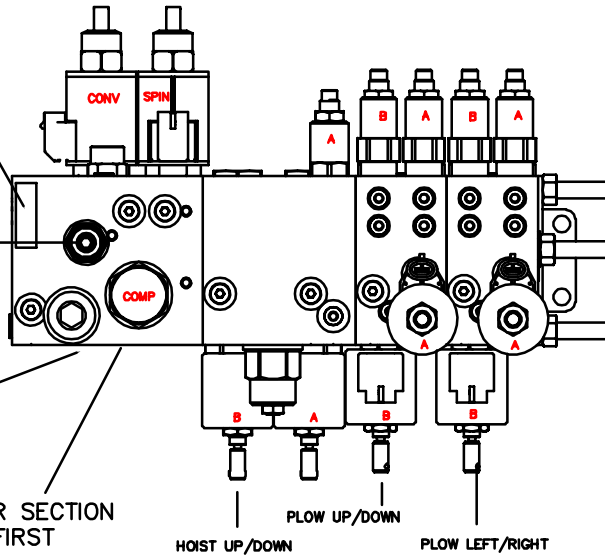

CYLINDER SECTIONS RUN FROM HIGH TO LOW FLOW

PORT "A" IS ALWAYS RETURN (ROD). EXAMPLES ARE HOIST DOWN, FLOW DOWN, TOE DOWN, HEEL DOWN, AND BLADE DOWN.

PORT "B" IS ALWAYS POWER (BASE). EXAMPLES ARE HOIST UP, FLOW UP, TOE UP, HEEL UP, AND BLADE UP.

SECTION DETAILS ON FOLLOWING PAGES

BLOCK OPTIONS:

- 00, 00C, 01, 02, 03, 04
- 05, 07, 09
- 05, 09
- 06, 08
- 06
- 06, 08
- 06, 08
- 06, 08
- 06
- 06, 08
- 06

MANIFOLD STANDARD LAYOUT:

- SPREADER BLOCK / INLET
- HOIST (OR HOOK) UP / DOWN
- HOOK JIB IN / OUT (IF PRESENT)
- PLOW UP/DOWN
- PLOW LEFT / RIGHT
- WING TOE
- WING HEEL
- WING BENCH (IF PRESENT)
- BLADE UP / DOWN
- BLADE LEFT / RIGHT

BLOCK DETAILS CAN BE FOUND ON THE FOLLOWING PAGES BY ADDING AN HYDJ IN FRONT OF THE ABOVE NUMBERS. AN EXAMPLE IS HYDJ05

ASSEMBLY PART NUMBER BREAK OUT

HYDJ1

03

05

06

06

CIRUS MANIFOLD
SYSTEM DESIGNATOR

SPREADER OR
INLET BLOCK #

HIGH FLOW OR
HOIST BLOCK #

CYLINDER
BLOCK 1 #

CYLINDER
BLOCK 2 #

ORDER DATE:

ORDER #:

HYD ASSEMBLY P/N#:

REV	DATE	DESCRIPTION
A	1-12-08	ADDED PORT NOTES
B	-	-
C	-	-
D	-	-
E	-	-

DESIGN:	JTM	DRAWN:	JTM	AS BUILT:	-
---------	-----	--------	-----	-----------	---

THIS DRAWING IS THE PROPERTY OF CIRUS CONTROLS. THIS IS TO BE CONSIDERED CONFIDENTIAL AND PROPRIETARY NO REPRODUCTION IN WHOLE OR PART WITH OUT PERMISSION IS ALLOWED.

CIRUS CONTROLS LLC	Phone: (763) 493-9380
	Fax: (763) 493-9340
9210 WYOMING AVE. N. SUITE 200 BROOKLYN PARK, MN 55445	
MANIFOLDS	
OVERVIEW	
PROJECT NUMBER: OVERVIEW	SCALE: NONE
DATE: 1-12-08	REV. A
SHT 1 OF 1	

NOTES:
1. PORT SIZES:
A, B.....SAE-12

B COIL

A COIL

TOP VIEW

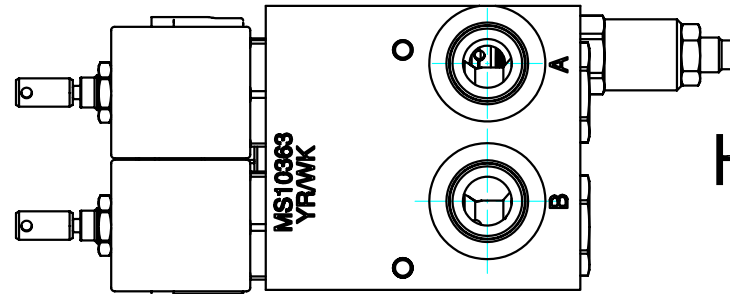
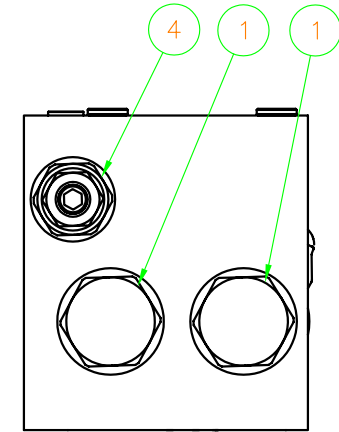
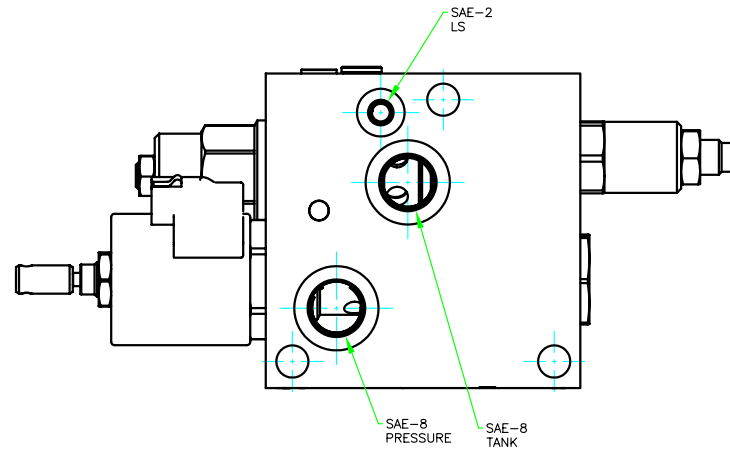
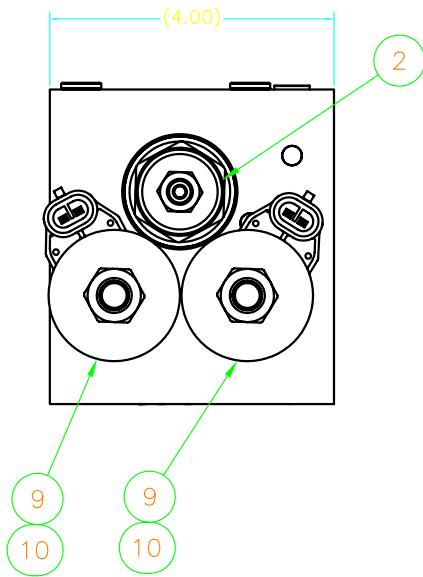
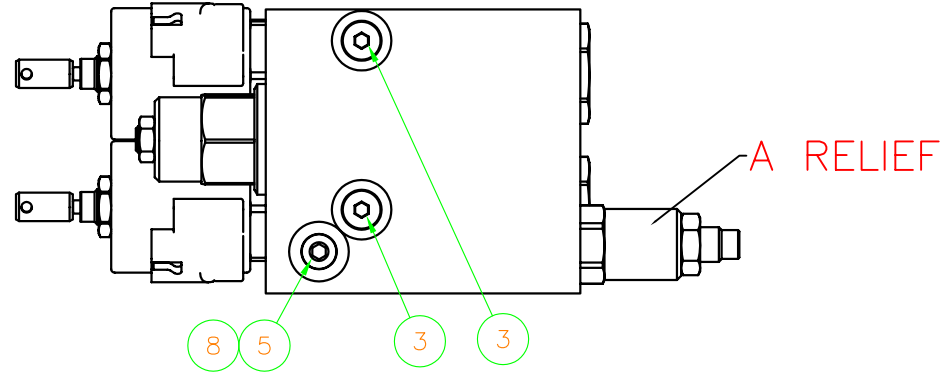

HYDJ05 / SA10049

Item	PART NUMBER	Qty	DESCRIPTION	TORQUE	SEAL KIT
10	SP16-20M-0-N-00	2	PROPORTIONAL VALVE	50 FT LBS	SK16-2N-T
9	4303512	2	COIL, 12VDC, METRIPACK	5 FT LBS	NA
8	OR10035-015	1	ORIFICE WITH SCREEN	NA	NA
7	MS10363	1	MANIFOLD	NA	NA
6	MB800-070	7	EXPANDER PLUG	NA	NA
5	6118004	1	PLUG, NWD-4	20 FT LBS	NA
4	RV10-22A-0-N-13/5	1	RELIEF VALVE, 500 PSI	25 FT LBS	SK10-2N-T
3	CV04-20-0-N-4	2	CHECK VALVE	5 FT LBS	SK04-2N-T
2	CBGH-LJN	1	COUNTERBALANCE VALVE	150 FT LBS	990-017-007
1	CV12-20-0-N-5	2	CHECK VALVE	30 FT LBS	SK12-2N-T

BILL OF MATERIAL

CIRUS Phone: (763) 493-9380
CONTROLS LLC Fax: (763) 493-9340
9210 WYOMING AVE. N. SUITE 200
BROOKLYN PARK, MN 55445

HYDRAULIC VALVE

DA HOIST 35-40 GALLONS

THIS DRAWING IS THE PROPERTY OF CIRUS CONTROLS.
THIS IS TO BE CONSIDERED CONFIDENTIAL AND
PROPRIETARY NO REPRODUCTION IN WHOLE OR PART
WITH OUT PERMISSION IS ALLOWED.

REV	DATE	DESCRIPTION
A	-	-
B	-	-
C	-	-
D	-	-
E	-	-

DESIGN:	DRAWN:	AS BUILT:	PROJECT NUMBER:	SCALE:	DATE:	REV.
JTM	JTM	-	HYDJ05	NONE	7-20-06	-
						SHT 1 OF 1

NOTES:
1. PORT SIZES:
A, B.....SAE-8

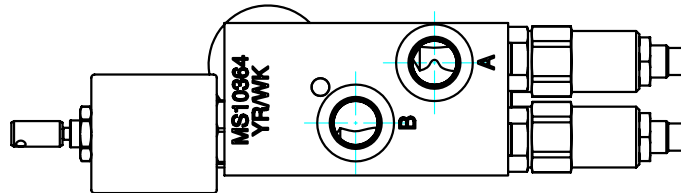
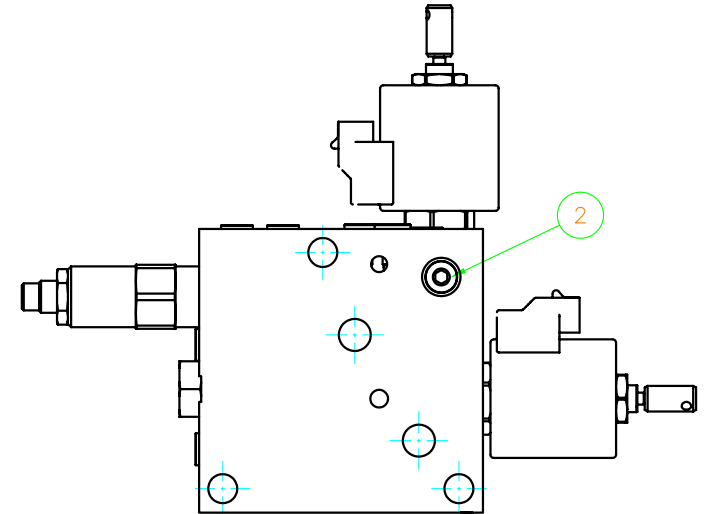
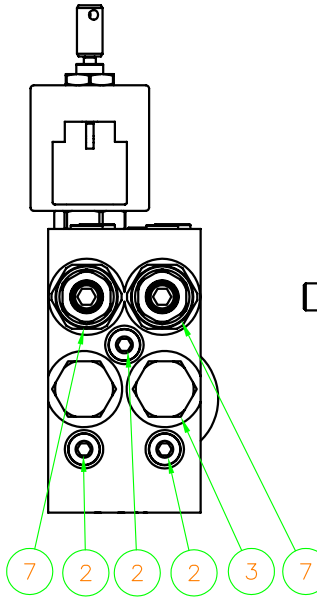
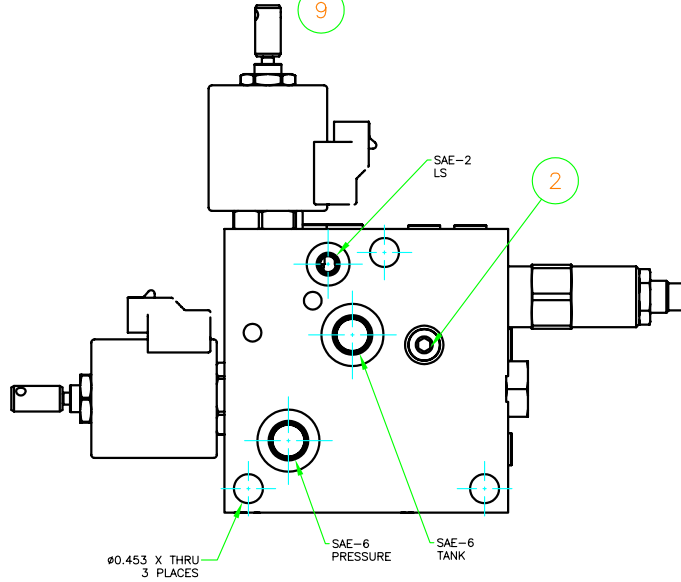
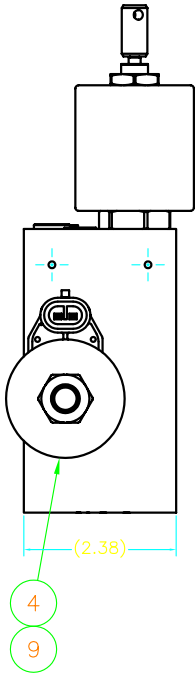
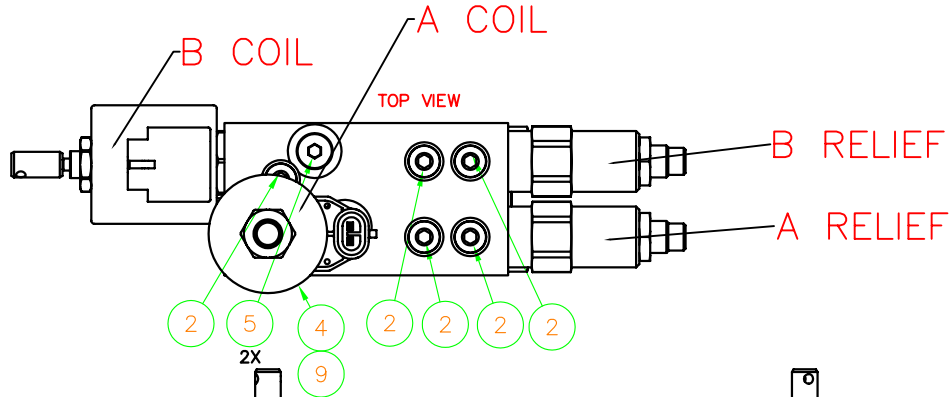

HYDJ06 / SA10050

9	SP10-20M-0-N-00	2	PROPORTIONAL VALVE	25 FT LBS	SK10-2N-T
8	SP10048	2	PILOT PISTON	NA	NA
7	RV08-22A-0-N-28/10	2	RELIEF VALVE	20 FT LBS	SK08-2N-T
6	MB800-070	5	EXPANDER PLUG	NA	NA
5	CV04-20-0-N-4	2	CHECK VALVE	5 FT LBS	SK04-2N-T
4	4303512	2	COIL, 12VDC, METRIPACK	5 FT LBS	NA
3	CV08-20-0-N-4	2	CHECK VALVE	20 FT LBS	SK08-2N-T
2	B118004	10	PLUG, NWD-4	20 FT LBS	NA
1	MST0364	1	MANIFOLD	NA	NA
Item	PART NUMBER	Qty	DESCRIPTION	TORQUE	SEAL KIT

BILL OF MATERIAL

THIS DRAWING IS THE PROPERTY OF CIRUS CONTROLS.
THIS IS TO BE CONSIDERED CONFIDENTIAL AND
PROPRIETARY NO REPRODUCTION IN WHOLE OR PART
WITH OUT PERMISSION IS ALLOWED.

REV	DATE	DESCRIPTION
A	-	-
B	-	-
C	-	-
D	-	-
E	-	-

DESIGN:	DRAWN:	AS BUILT:
JTM	JTM	-

CIRUS CONTROLS LLC 9210 WYOMING AVE. N. SUITE 200 BROOKLYN PARK, MN 55445	Phone: (763) 493-9380 Fax: (763) 493-9340
	HYDRAULIC VALVE
	DA CYLINDER 10-15 GALLONS
PROJECT NUMBER: HYDJ06	SCALE: NONE
DATE: 7-20-06 SHT 1 OF 1	REV: -

NOTES:
1. PORT SIZES:
SAE-10

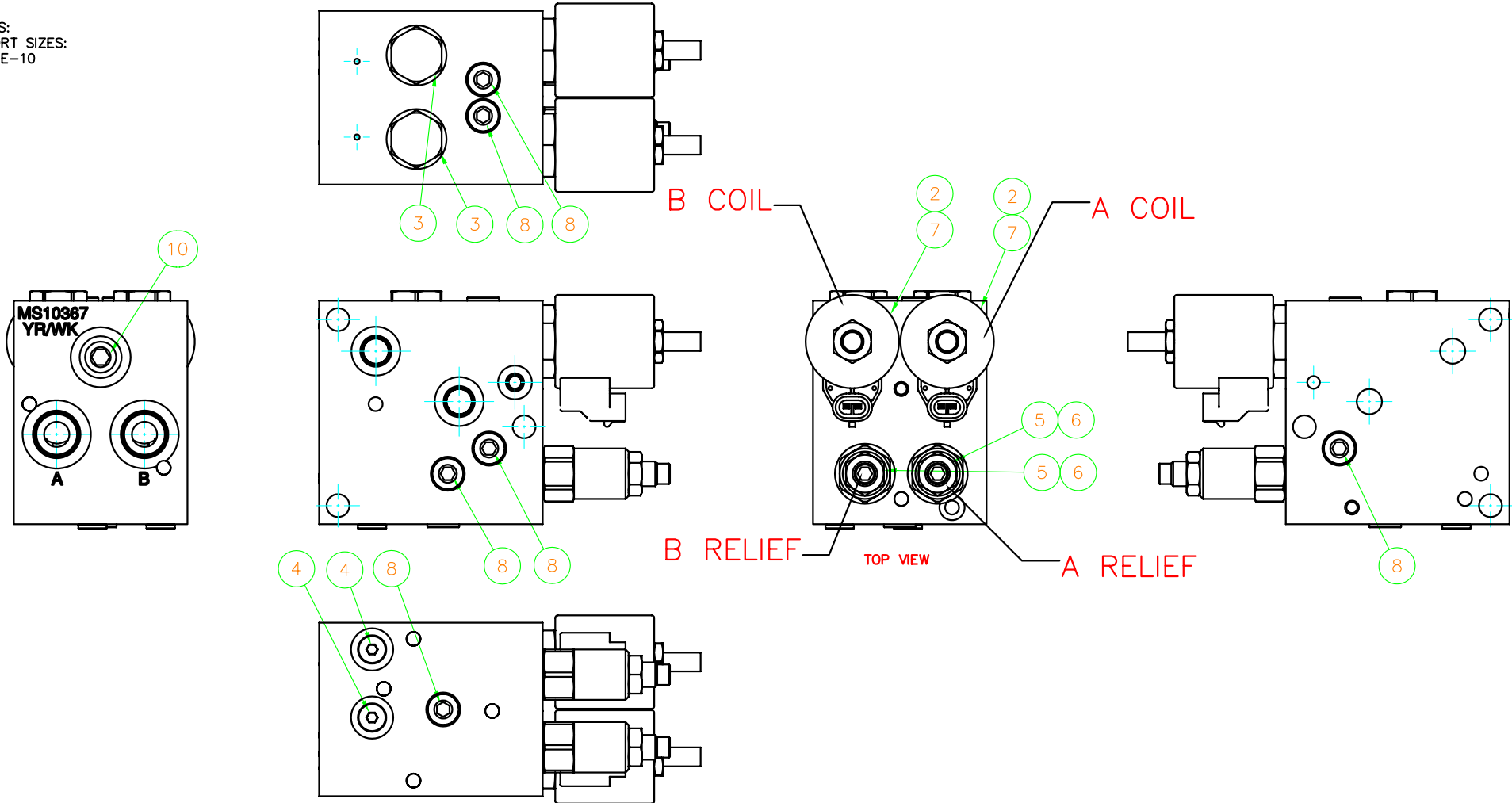

HYDJ09 / SA10056

Item	PART NUMBER	Qty	DESCRIPTION	TORQUE	SEAL KIT
10	6118008	1	PLUG, NWD-8	50 FT LBS	NA
9	MB800-070	13	EXPANDER PLUG	NA	NA
8	6118006	6	PLUG, NWD-6	25 FT LBS	NA
7	4303512	2	COIL, 12VDC, METRIPACK	5 FT LBS	NA
6	PT10004	2	PILOT PISTON	NA	NA
5	RV10-22A-0-N-25/10	2	RELIEF VALVE	25 FT LBS	SK10-2N-T
4	CV04-20-0-N-4	2	CHECK VALVE	5 FT LBS	SK04-2N-T
3	CV10-21-0-N-5	2	CHECK VALVE	25 FT LBS	SK10-2N-B
2	SP12-20M-0-N-00	2	PROPORTIONAL VALVE	35 FT LBS	SK12-2N-T
1	MS10367	1	MANIFOLD	NA	NA

BILL OF MATERIAL

CIRUS Phone: (763) 493-9380
CONTROLS LLC Fax: (763) 493-9340
 9210 WYOMING AVE. N. SUITE 200
 BROOKLYN PARK, MN 55445

THIS DRAWING IS THE PROPERTY OF CIRUS CONTROLS.
 THIS IS TO BE CONSIDERED CONFIDENTIAL AND
 PROPRIETARY. NO REPRODUCTION IN WHOLE OR PART
 WITH OUT PERMISSION IS ALLOWED.

REV	DATE	DESCRIPTION
A	-	-
B	-	-
C	-	-
D	-	-
E	-	-

DESIGN:	DRAWN:	AS BUILT:	PROJECT NUMBER:	SCALE:	DATE:	REV.
JTM	JTM	-	HYDJ09	NONE	7-20-06	-

HYDRAULIC VALVE

DA CYLINDER 20-25 GALLONS

SHT 1 OF 1